

- ① LINK BOX
- ② EARTHING BUS BAR
- ③ C.B. LINKS
- ④ DISCONNECTABLE S.A.
- ⑤ SINGLE BONDING CABLE

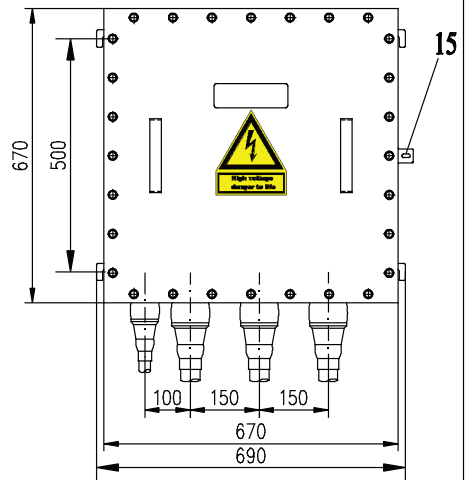
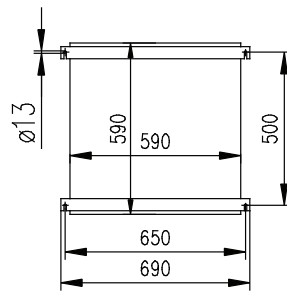

LIST OF MAIN PARTS

Item	Name of parts	Materials
1	CABINET (2mm)	STAINLESS STEEL
2	SURGE ARRESTER	ZnO
3	SUPPORT INSULATORS	EPOXY
4	GLAND FOR COAXIAL CABLE	STAINLESS STEEL
5	GLAND FOR EARTHING CABLE	STAINLESS STEEL
6	FLEX LINK BAR	TINNED COPPER
7	CABLE END FIXING CLAMP	TINNED COPPER
8	BUS BARS (10x40)	TINNED COPPER
9	DISCONNECTABLE EARTHING BAR (10x40)	TINNED COPPER
10	EARTHING BAR BRIDGE TYPE (10x40)	TINNED COPPER
11	PROTECTION COVER	PLEXYGlass
12	BOX EARTHING BAR	STAINLESS STEEL
13	BLOCKING ROD OF INCORRECT POS.	POLIAMIDE
14	HEAT SHRINKABLE TUBE	MWTD
15	PADLOCK FACILITY	STAINLESS STEEL
16	COVER (3mm)	STAINLESS STEEL

Specifications	
Protection degree	IP68
DC Voltage test	25 kV-5 min.
Short circuit test	50 kA-1 sec.
Internal power arcing	40 kA-0,1 sec.
Impulse voltage between parts	75 kV
Impulse voltage against earth	40 kV
*SA rate (Politek-PMSP)	up to 15 kV
Bonding cable (Single)	95-400 mm ²
**Inner Core Insulation Dia.(Min.-Max.)	
**Screen Wires Dia.(Min.-Max.)	
**Outer Dia.(Min.-Max.)	17-40
Weight	app. 70 Kg.
Volume of Filling compound (optional)	
Colour	RAL 7032

*Indicate, if different SA (SVLs) required...
 **Indicate, if bonding cable different size...

Rev.	Date	Drawn	Check	Apprv.	
D					
C					
B	21.03.10	F.CABAROGLU	SERDENZ	SERDENZ	Padlock Shown, thickness Dimension mentioned
A	01.08.09	F.CABAROGLU	SERDENZ	SERDENZ	Cable glands modified

CROSS BONDING LINK BOX FOR UNDERGROUND TYPE LB.U.CB.3SA.6.1	08.01.06 Rev. B
	Drawn : 23.01.2008 / F.C. Approved : 23.01.2008 / S.E.