

- ① LINK BOX
- ② EARTHING BUS BAR
- ③ DISCONNECTABLE BAR
- ④ COAXIAL BONDING CABLE

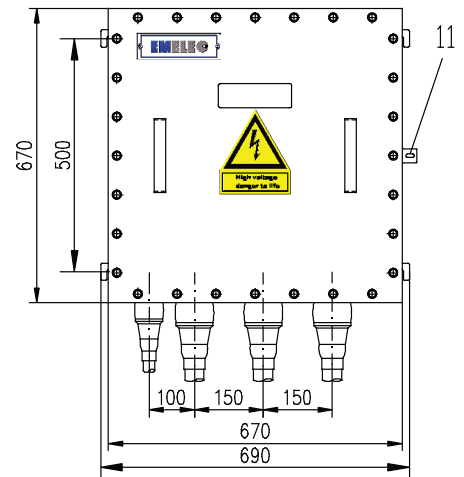

LIST OF MAIN PARTS

Item	Name of parts	Materials
1	CABINET (2 mm)	STAINLESS STEEL
2	SUPPORT INSULATORS	EPOXY
3	GLAND FOR COAXIAL CABLE	STAINLESS STEEL
4	GLAND FOR EARTHING CABLE	STAINLESS STEEL
5	FIXING CLAMP	TINNED COPPER
6	CABLE END FIXING CLAMP	TINNED COPPER
7	EARTHING BUS BAR(10x40)	TINNED COPPER
8	DISCONNECTABLE CROSSING BAR(10x40)	TINNED COPPER
9	PROTECTION COVER	PLEXYGLOSS
10	BOX EARTHING BAR	STAINLESS STEEL
11	PADLOCK FACILITY	STAINLESS STEEL
12	HEAT SHRINKABLE TUBE	MWTD
13	DOOR FIXING BOLTS	STAINLESS STEEL
14	COVER (3 mm)	STAINLESS STEEL

Specifications	
Protection degree	IP68
DC Voltage test	25 kV-5 min.
Short circuit test	50 kA-1 sec.
Internal power arcing	40 kA-0,1 sec.
Impulse voltage between parts	N / A
Impulse voltage against earth	40 kV
*SA rate (Politek-PMSP)	N / A
Bonding cable (Coaxial)	95-400 mm <sup>2</sup>
**Inner Core Insulation Dia.(Min.-Max.)	Ø20-Ø36
**Screen Wires Dia.(Min.-Max.)	Ø25-Ø48
**Outer Dia.(Min.-Max.)	Ø30-Ø64
Weight	app. 68 Kg.
Volume of Filling compound (optional)	app. 57 Lt.
Colour	RAL 7032

\*Indicate,if different SA (SVLs) required...  
 \*\*Indicate,if bonding cable different size...

Rev.	Date	Drawn	Check	Appr.	Notes
D					
C	21.03.10	F.CABAROGLU	SERDENIZ	SERDENIZ	Cable gland sealing, earthing cable center dimension changed
B	28.04.08	F.CABAROGLU	SERDENIZ	SERDENIZ	Box Dimension Changed
A	11.05.07	F.CABAROGLU	SERDENIZ	SERDENIZ	Padlock Shown, thickness & Dimension mentioned

<b>Earthing Bonding Link Box</b>		<b>04.09.07 Rev. C</b>
FOR UNDERGROUND TYPE		Drawn : 04.11.2004 / F.C.
TYPE :LB.U.E.3.1		Approved : 04.11.2004 / S.E.