

- ① LINK BOX
- ② EARTHING BUS BAR
- ③ LINKS
- ④ DISCONNECTABLE SA
- ⑤ COAXIAL BONDING CABLE

LIST OF MAIN PARTS

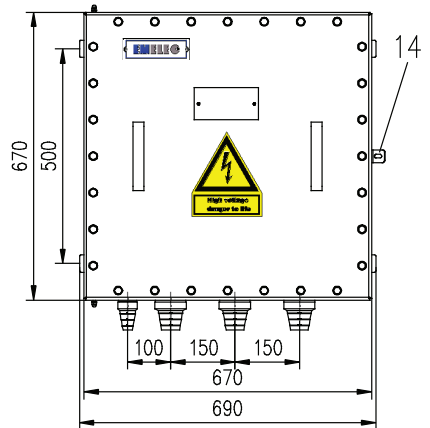

Item	Name of parts	Materials
1	CABINET (3 mm)	STAINLESS STEEL
2	SURGE ARRESTER	ZnO
3	SUPPORT INSULATORS	EPOXY
4	GLAND FOR COAXIAL CABLE	STAINLESS STEEL
5	GLAND FOR EARTHING CABLE	STAINLESS STEEL
6	CABLE END FIXING CLAMP	TINNED COPPER
7	BUS BARS (10x40)	TINNED COPPER
8	SUPPORT BAR (10x40)	TINNED COPPER
9	ADJUSTABLE SUPPORT BAR (10x40)	TINNED COPPER
10	COAXIAL FIXING CLAMP	TINNED COPPER
11	PROTECTION COVER	PLEXYGLASS
12	BOX EARTHING BAR	STAINLESS STEEL
13	DOOR FIXING BOLTS	STAINLESS STEEL
14	PADLOCK FACILITY	STAINLESS STEEL
15	COVER (3 mm)	STAINLESS STEEL

Specifications	
Protection degree	IP68
DC Voltage test	25 kV-5 min.
Short circuit test	N / A
Internal power arcing	40 kA-0,1 sec.
Impulse voltage between parts	75 kV
Impulse voltage against earth	40 kV
*SA rate (Politek-PMSP)	up to 10 kV
Bonding cable (Coaxial)	95-400 mm ²
**Inner Core Insulation Dia.(Min.-Max.)	ø25-ø36
**Screen Wires Dia.(Min.-Max.)	ø25-ø48
**Outer Dia.(Min.-Max.)	ø30-ø64
Weight	app. 88 Kg.
Volume of Filling compound (optional)	app. 58 Lt.
Colour	RAL 7032

*Indicate, if different SA (SVLs) required...
 **Indicate, if bonding cable different size...

Rev.	Date	Drawn	Check	Apprv.
D				
C				
B				
A				

**Single Point Bonding Link Box
 FOR UNDERGROUND TYPE
 TYPE :LB.U.SB.6SA.3.1**

11.02.06 Rev. 0
 Drawn : 28.02.2011 / F.C.
 Approved : 28.02.2011 / S.E.