

FOR THE CABLE DIAMETER

TYPE	ØD min-max	A	B	C	E	F	G	H	M1	M2	WEIGHT
EMELEC-3AFXC-01	Ø30-40	159	179			79	100	118-138			1.045 gr.
EMELEC-3AFXC-02	Ø40-50	179	199			89	110	135-155	M8x60	M8x110	1.200 gr.
EMELEC-3AFXC-03	Ø50-60	199	219	12-22	45	99	120	155-175			1.350 gr.
EMELEC-3AFXC-04	Ø60-70	219	239			109	130	175-195	M10x60	M10x130	1.500 gr.
EMELEC-3AFXC-05	Ø70-80	239	259			119	140	195-215			1.600 gr.
EMELEC-3AFXC-06	Ø80-90	281	311			145	166	220-240			3.150 gr.
EMELEC-3AFXC-07	Ø90-100	301	331			155	176	240-260		M12x150	3.350 gr.
EMELEC-3AFXC-08	Ø100-110	321	351	16-26	60	165	186	260-280	M12x70		3.550 gr.
EMELEC-3AFXC-09	Ø110-120	341	371			175	196	280-300		M12x170	3.800 gr.
EMELEC-3AFXC-10	Ø120-130	361	391			185	206	300-320			4.000 gr.
EMELEC-3AFXC-11	Ø130-140	401	431	18-28	90	205	226	336-356	M16x80	M16x185	8.040 gr.
EMELEC-3AFXC-12	Ø140-150	421	451			215	236	356-376			8.390 gr.

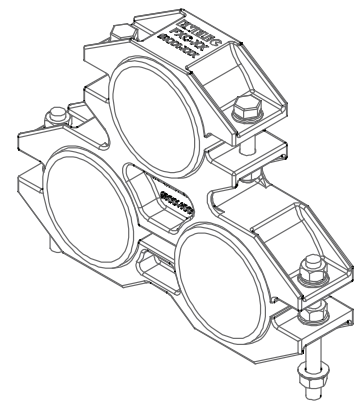

LIST OF MAIN PARTS

Item	Name of parts	Materials	Qty.
1	LOWER PART	AL8-SiMn10	1
2	MIDDLE PART	AL8-SiMn10	1
3	UPPER PART	AL8-SiMn10	1
4	PROTECTION	EPDM RUBBER	6
5	HEX. HEAD SCREW	Galvanized-STEEL	2
6	SCREW	Galvanized-STEEL	2
7	HEX NUT	Galvanized-STEEL	8
8	WASHER	Galvanized-STEEL	10
9	SPRING WASHER	Galvanized-STEEL	4

Rev.	Date	Drawn	Check	Appr.

TREFOIL CABLE FIXING CLAMP **09.10.04** Rev. **0**
MODEL - A -
EMELEC-3AFXC

Drawn : 24.10.2009 / F.C.
 Approved : 24.10.2009 / S.E.